



**Single Handle Tub/Shower Pressure Balancing Valve**

- 1/2" PEX Inlet W/Combo CXC & IPS Outlet
- Pressure Balancing Cartridge Ships with Trims
- Stainless Steel Mounting Bracket
- Test Cap allows Pressure Testing 150 PSI Max
- Square Mud Guard with Leveler allows right angle cuts
- Thin Wall Mounting
- Back to Back Installation

Olympia products are engineered and manufactured to meet the following standards and codes :  
ASME A112.18.1/ CSA B125.16  
ASSE 1016  
IAPMO LISTED



Note: Valve can be tested When Test Cap installed with air (150 PSI) or water (150 PSI).

Note: Cartridge operational at pressures 20 PSI to 100 PSI.

V-2405B Flow Rate (GPM) Vs Pressure (PSI) For Tub Port\*

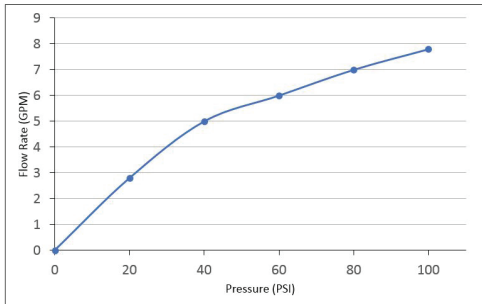

\*Note: This information is provided for reference only. Actual Flow Rate may vary depending on installation and inlet pressures.

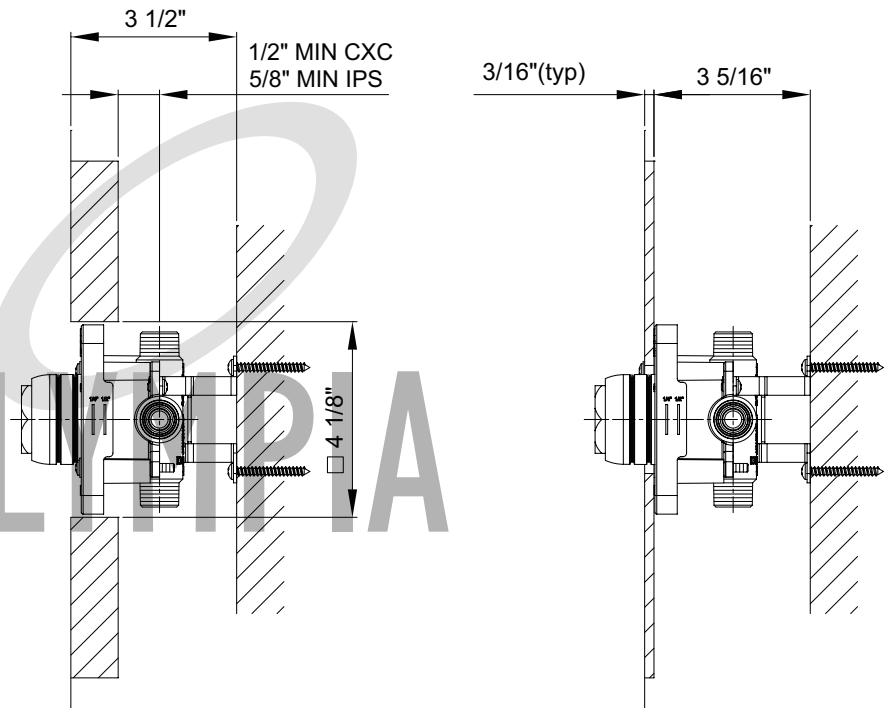
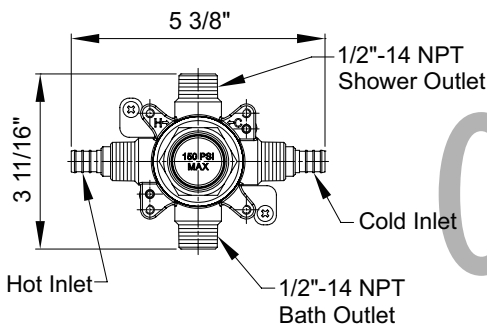

THICK WALL

THIN WALL